

NOTES:

1. All dimensions are in millimetres unless otherwise stated.
2. Timber shall be as Clause 311 of the Specification.

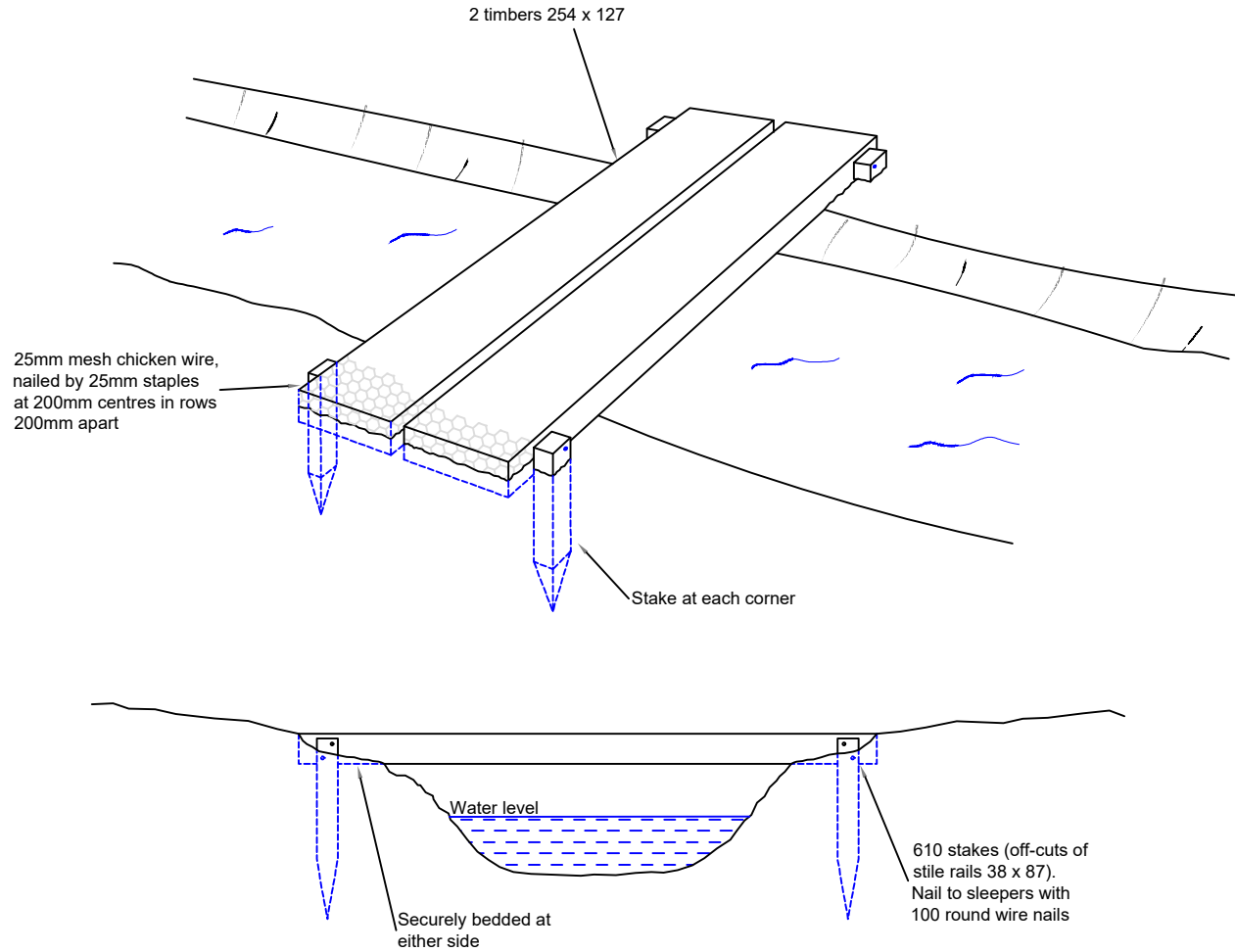

Rev.	Description	Drawn	Ch'kd	Auth	Date



in partnership with



www.viaem.co.uk Tel 0115 804 2100

Bilthorpe Depot, Bilthorpe Business Park, Bilthorpe, Nottinghamshire, NG22 8ST

Project		Highway Construction Details			Project	Drawn	Date
Status	Project No.	Rights of Way			JLS	18/08/2020	
Drawing Title		DSB-Double "Sleeper" Bridge			JD	16/02/2021	
Drawing No.		SD/FP/08			JP	HR	
					0	N.T.S @A4	