

ELEVATION

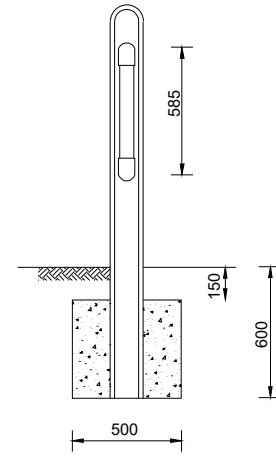

FOUNDATION DETAIL

ALTERNATIVE FOUNDATION DETAIL IN PAVED AREA

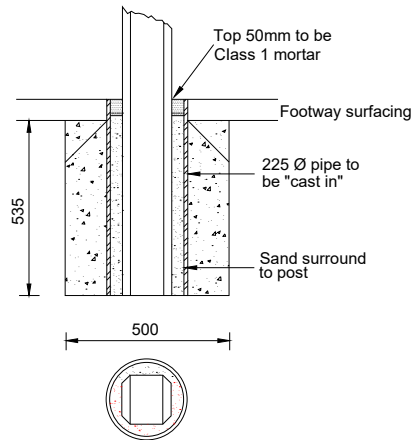

NOTES:

1. All dimensions are in millimetres unless otherwise stated.
2. Where directed painting shall be white masonry paint on posts and railings to be painted using 'Finnegan's' or similar galvanised metal primer plus top coat of white 'Hammerite' using a second coat where required within 3 hours. Paint to be applied in accordance with manufacturers recommendations.
3. Edge of excavation to be used as formwork for grade C15 concrete foundation up to 150mm of existing ground level. To be 'topped off' using 'as dug' topsoil from excavation.
4. Where brook railing posts are to be set in paved or concreted areas the alternative foundation detail to be used.

Rev.	Description	Drawn	Ch'kd	Auth	Date



in partnership with



www.viaem.co.uk Tel 0115 804 2100

Bilsthorpe Depot, Bilsthorpe Business Park, Bilsthorpe, Nottinghamshire, NG22 8ST

Project		Highway Construction Details			Project	Drawn	Date
Status	Project No.	Fencing			JLS	20/08/2020	
Drawing Title		Brook Railings			JD	29/01/21	
Drawing No.		SD/3/21			JJP	JLS	
					Rev.	0	Scale
							N.T.S @A4