

NOTES:

1. All dimensions are in millimetres unless otherwise stated.
2. Ducts to be a minimum internal diameter of 100mm, smooth bore.
3. Concrete markers shall be sited clear of the underside of safety fences and street furniture.
4. All ducts to incorporate a 10mm polypropylene draw rope tied to the steel eye of the marker block. Knotted joints along the length of the rope will not be permitted.
5. A minimum of 1m slack rope should be coiled under each marker block.
6. The ends of the duct shall be sealed with manufactured end plates/stoppers and drilled to enable the draw rope to be threaded through.
7. The routing and clearances of duct in relation to services and drainage pipes shall be agreed with the Engineer prior to backfill.
8. Testing - prior to surfacing of the carriageway the duct shall be tested and cleaned by drawing through a suitable rag mop.
9. On Department of Transport road schemes marker blocks shall be labelled in accordance with the current Highway Construction Details.
10. Where ducts terminate in splitter islands, duct marker blocks shall be replaced with duct chambers or as directed by the Engineer.
11. Where ducts are laid below existing carriageways, the pavement layers should be reinstated in accordance with the Specification.

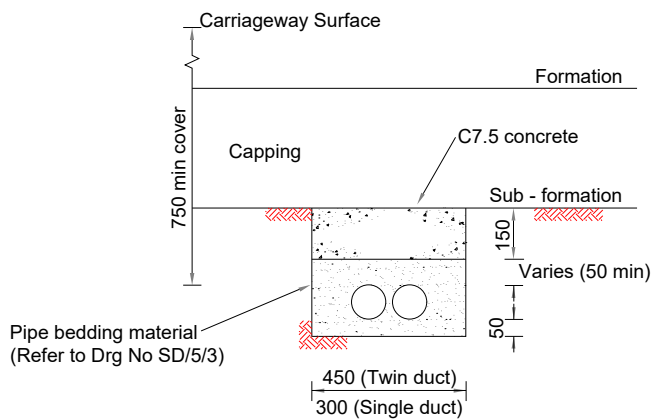

DUCTS LAID PRIOR TO CAPPING

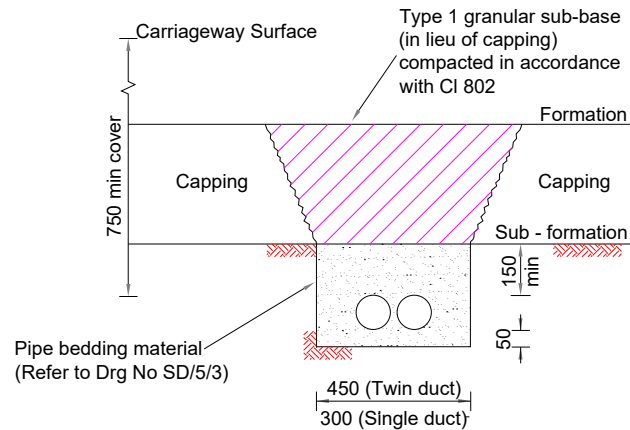

DUCTS LAID AFTER CAPPING OR IN EXISTING CONSTRUCTION

Rev.	Description	Drawn	Ch'kd	Auth	Date

 in partnership with

www.viaem.co.uk Tel 0115 804 2100
 Bilsthorpe Depot, Bilsthorpe Business Park, Bilsthorpe,
 Nottinghamshire, NG22 8ST

Project		Highway Construction Details		Project	
Status	Project No.	Drawn	Date	Ch'kd	Date
		JLS	12/06/2020	JD	01/07/20
Drawing Title		Auth	Traced	JJP	JLS
Drawing No.		Rev.	Scale	0	N.T.S @A4