

NOTES:

1. All dimensions are in millimetres unless otherwise stated.
2. (a) Cycleways constructed alongside existing carriageways: The joint between the carriageway and the cycleway surfacing shall be along the line 'A-A'. The edge of the existing wearing course should be cut-back to a clean vertical face and coated with a hot bituminous binder prior to laying cycleway surfacing.

(b) Cycleways constructed alongside existing carriageways: The wearing course and base course of the carriageway should be raked out to a line 'A-A' and cut-back to a clean vertical face and coated with a hot bituminous binder prior to laying cycleway surfacing.
3. Where the cycleway falls away from the carriageway, a side entry gully shall be constructed as shown at the low point. The gully shall be a side entry Glynwed Aquakerb D400 or similar approved.

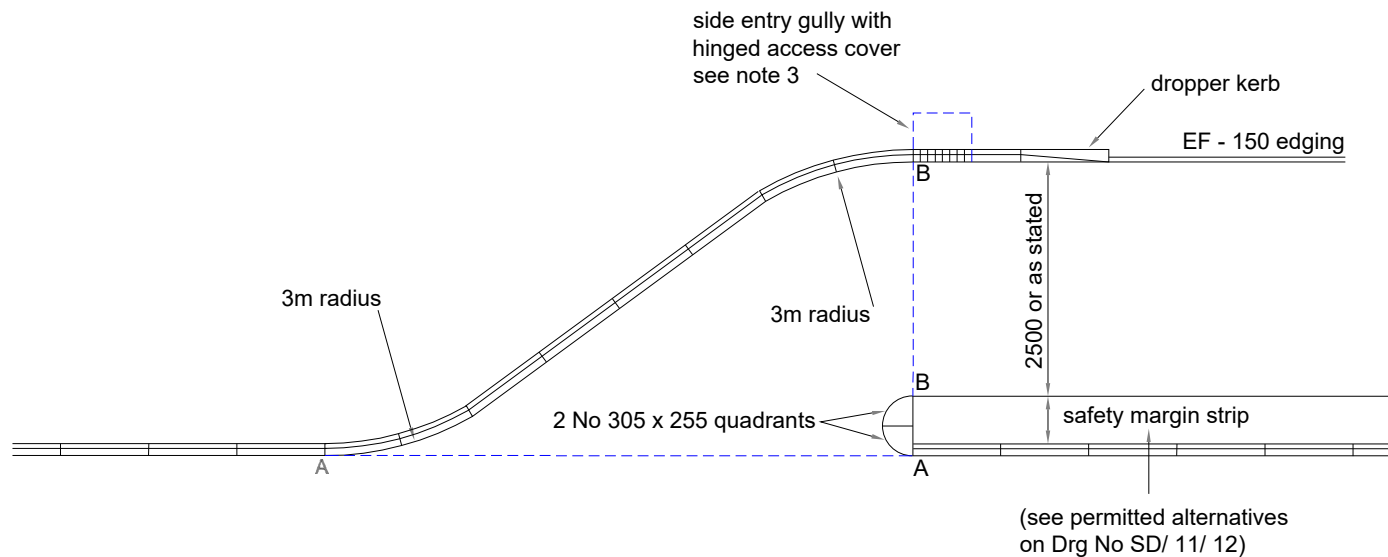

Rev.	Description	Drawn	Ch'kd	Auth	Date

via in partnership with **Nottinghamshire County Council**

www.viaem.co.uk Tel 0115 804 2100
Bilthorpe Depot, Bilthorpe Business Park, Bilthorpe, Nottinghamshire, NG22 8ST

Project		Highway Construction Details			Project	Drawn	Date
Status	Project No.	Kerbs, Footways And Pavings				JLS	16/06/2020
Drawing Title		Start Of Cycleway On Principle And Major Routes			Auth	JD	Date
Drawing No.		SD/11/15			JP	Traced	JLS
					Rev.	0	Scale
							N.T,S @A4