

Cross section

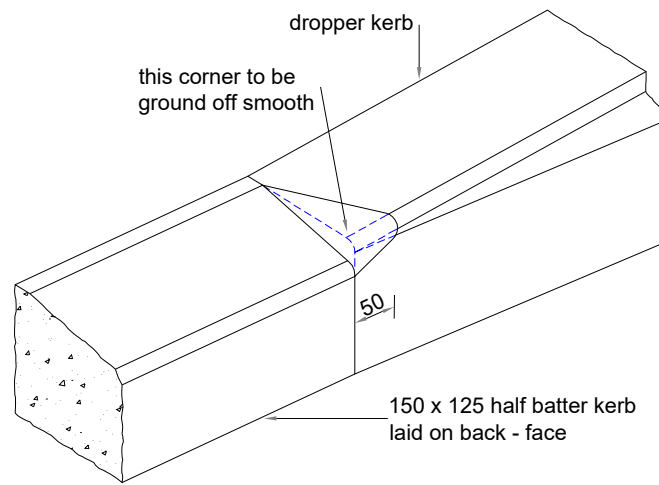

Kerb detail

NOTES:

1. All dimensions are in millimetres unless otherwise stated.
2. For kerb construction details see Drg SD/11/2.
3. The 150 x 125 half batter kerb was formerly designated as a PC9 on BS 340.
4. At the start of the cycleway or other locations where cyclists will be joining the cycleway at acute angles the number of flush kerbs should be increased to minimum of four.
5. Where specified, on new carriageways a 255 x 125 channel blocked to be laid over the width of the crossing. Foundation as per Drg SD/11/2

Rev.	Description	Drawn	Ch'kd	Auth	Date



in partnership with



**Nottinghamshire
County Council**

www.viaem.co.uk Tel 0115 804 2100

Bilsthorpe Depot, Bilsthorpe Business Park, Bilsthorpe,
Nottinghamshire, NG22 8ST

Project		Highway Construction Details			Project	Drawn	Date
Status	Project No.	Kerbs, Footways And Paving			JLS	JLS	16/06/2020
Drawing Title		Flush Dropped Crossings - Type B			JD	JD	30/07/20
Drawing No.		SD/11/08			JP	JP	JLS
					0	0	N.T.S.@A4