

in partnership with



**Nottinghamshire
County Council**

HIGHWAYS ACT 1980 SECTIONS 169, 172, 173 & 174

APPLICATION FOR A LICENCE to; Erect and Maintain Scaffold or Hoarding/Use Mobile Tower Scaffold/Use Mobile Access Platform Or Store Materials On The Highway

To ensure minimum delay to application, please return the following items - ASAP	Tick if provided
Fully Completed and Signed Application Form	
Valid Proof of Public Liability Insurance <u>(See point 9 of Conditions)</u>	
Plan of works showing full extent of proposed erection	
Payment: (Delete as necessary) Cheques made payable to Via East Midlands BACs details (available up on request) Phone Payment (0115 9934602) Invoice (available upon request, additional £7 charge)	

Please note the following:

- We require **5 working days**' notice to process your application
- There may be a delay with processing your application if it is submitted without any of the above

Please send completed application forms through to:

Highways Authorisations Team
Trent Bridge House
C/O County Hall
Loughborough Road
West Bridgford
Nottingham
NG2 7QP

licences@viaem.co.uk

in partnership with



Nottinghamshire
County Council

HIGHWAYS ACT 1980 SECTIONS 169, 172, 173 & 174

APPLICATION FOR A LICENCE to; Erect and Maintain Scaffold or Hoarding/Use Mobile Tower Scaffold/Use Mobile Access Platform Or Store Materials On The Highway

APPLICATION

I/We apply for a Licence to erect and maintain a scaffold/hoarding/mobile tower scaffold/mobile access platform/ store materials on the highway for the purpose of.....

The *scaffold/hoarding/mobile tower scaffold/mobile access platform/materials (*please delete as necessary) is to be located at:

..... Scaffold/hoarding/tower/storage type:.....

..... Length:m Height:.....m

..... Width:m Width of f/way:m

Proposed erection date:/...../..... Removal:/...../.....

A location plan showing the exact position of the scaffold/hoarding is required prior to any licence being issued. Please note if we do not receive a plan, your application may be delayed.

DECLARATION

I/We have received a copy of 'Via on behalf of Nottinghamshire County Council' Standard Conditions for the erection of scaffolding/hoarding on the highway giving my/our undertaking to observe and abide by the conditions contained within that document as well as any other additional conditions which may be listed as part of the licence including the payment of the associated fees.

I/We declare that a valid Public Liability Insurance with a limit of **NO LESS THAN £5,000,000** is held by me/us, and the Insurance carries an **Indemnity to Principal clause**, evidence to be provided with the application if not previously provided. I/We also declare that the Utilities have been consulted by me/us and agree to the proposals. I/We understand that the responsibility for ensuring compliance with the Health and Safety at Work Act, 1974 is that of the Licensee and his/her contractor and not of the Highway Authority or it's Agent.

Name and address of Applicant:

.....

..... Telephone Number:.....

Email Address:

Name, address and contact number of erector if different from Applicant:

.....

Signed: Print Name

Date:...../...../.....

in partnership with



**Nottinghamshire
County Council**

HIGHWAYS ACT 1980 SECTIONS 169, 172, 173 & 174

**APPLICATION FOR A LICENCE TO ERECT AND MAINTAIN SCAFFOLD/HOARDING ON THE
HIGHWAY – STANDARD CONDITIONS**

In order to erect and maintain scaffold/hoarding or other structure on or over the highway you are required to obtain a Licence for each location from Via on behalf of the Highway Authority. This will only be issued subject to your undertaking to observe and abide by the conditions listed below as well as any other conditions Via on behalf of the Highway Authority may deem necessary. Such additional conditions will be contained within the Licence itself. You should be aware that should you fail to observe and abide by these conditions then you will be liable to prosecution under the above named Act.

You should now read and familiarise yourself with the conditions listed below. Only when you have fully satisfied yourself that you understand these and undertake to observe and abide by them should you complete and sign the application. These conditions will then form part of the licence for its duration unless legislation or policy changes require their revision. If this should happen you will be required to give an undertaking to observe and abide by the revised conditions.

For the purpose of the Licence and these conditions the person making the application will be referred to as the 'licensee', the scaffold/hoarding or other structure referred to as the 'structure', the location and purpose of the structure referred to as the 'works', and the 'highway' deemed to include the footway, carriageway and areas to which the public have right of access.

CONDITIONS 1-17

1. Before a Licence is issued a site meeting may be required with the licensee and a representative of Via on behalf of the Highway Authority to discuss the proposals. If this is the case the licensee will be contacted with a view of arranging a meeting accordingly.
2. The structure and its component parts shall be in accordance with BSEN12811-1:2003, properly erected and maintained by the Licensee in a manner which causes minimum obstruction to users of the highway.
3. To avoid obstruction of access to Utilities apparatus, either for routine works or emergency repairs, it is essential that the Utilities are consulted regarding the positioning of the overlying structure. Their agreement to the proposals and to the procedures to be adopted in the event of the Utility requiring access to their apparatus in an emergency situation must be obtained before a Licence will be issued. Under no circumstances will base plates be allowed on the covers of access chambers and immediate action must be taken to relocate such members as soon as they are brought to the licensee's attention, **whatever the state of the erection at the time**. Via on behalf of The Highway Authority can provide a list of the Utilities operating in the area, however, this is to the best of their knowledge at that time and it is the licensee's responsibility to ensure that **all** the Utilities are consulted and agree to the proposals prior to the making of the application.
4. The licensee shall keep the structure in a safe condition.
5. The licensee shall afford Via on behalf of the Highway Authority such facilities as may reasonably be required for inspecting the structure.
6. The structure shall be used only for the purpose(s) specified on the Licence.



7. The licensee shall not do, permit or suffer to be done, upon or from the structure, anything which in the considered opinion of Via on behalf of the Highway Authority would, or would likely to, cause injury or damage or become a danger or nuisance to users of the highway or occupier of adjoining premises.
8. The licensee shall keep that part of the highway on or over which the structure is erected, free from damage and kept clean and tidy. Any damage caused to the highway or street furniture will be, on completion of the works, repaired to a satisfactory standard by the licensee otherwise remedial work will be undertaken by Via on behalf of the Highway Authority and the full cost of any such work including administrative charges will be charged to the Licensee.
9. **The licensee shall indemnify, and keep indemnified, the County Council or it's Agents as the Highway Authority against any liability, loss, claim or proceeding whatsoever arising under Statute or Common Law in respect of, or in consequence of, the erection, retention, collapse or removal of the structure, or the carrying out of works, and against all claims, demands, proceedings, damages, costs, charges and expenses whatsoever in respect thereof or in relation thereto. The sum covered by the policy to be £5million for any one event with a reputable insurer and in terms approved by Via on behalf of the Highway Authority, approval shall not be unreasonably withheld. Whenever required the Licensee shall produce to the Authority the policy, or policies of insurance and the receipts for payment of the current premises.**
10. In the event of the structure collapsing so as to cause a nuisance or obstruction on or over the highway, the licensee shall pay to Via on behalf of the Highway Authority such costs as may reasonably have been incurred by them in carrying out work required to remove any such nuisance or obstruction or otherwise make the highway safe for passage.
11. Following the introduction of the Local Authorities (Transport Charges) Regulations 1998 it is now practice for Highway Authorities to charge for consideration of applications for licences to erect and maintain scaffold/hoarding or other structures on or over the highway. Via on behalf of Nottinghamshire County Council therefore have the charges as shown on the attached calculation sheet. Please note that this charge must be paid before the licence becomes effective for works to commence on site. A copy of the charge calculation will be provided by Via on behalf of the Highway Authority with the Licence.
12. The Licence is personal to the licensee and is not transferable.
13. The Licence may be terminated by either party to this Licence giving not less than 48 hours' notice in writing to the other party.
14. The Licence may be revoked at any time by Via on behalf of the Highway Authority in the event of:
 1. Failure to remedy any defects brought to the attention of the licensee;
 2. Non-compliance with any of the conditions stated on the Licence.
15. Revocation of the Licence will be reported to the Police and the Health and Safety Executive as appropriate.
16. Upon completion of the works, or in the event of revocation of this Licence, the licensee shall forthwith remove the structure from the highway and leave the highway clean and tidy and free from damage.



17. The licensee has a right of appeal to a Magistrates Court against any conditions imposed under Sections 169 and 172 of the Highways Act.

**SECTIONS 169, 172, 173, 174 MINIMUM CONDITIONS (1-13) FOR A LIGHTWEIGHT
SCAFFOLD ON THE HIGHWAY UNDER THE HIGHWAYS ACT 198 AND BRITISH
STANDARD 5973 1990**

1. Sole Boards to be used at all times, preferably Full Boards running through two standards or a minimum of 450 x 225, if this is not possible.
2. Sole Plates to be used at all times and to be a minimum of 150 x 150.
3. There should be a minimum of 2.4m from Sole Board to the first ledger, unless otherwise instructed.
4. From ground level standards should be painted with Black and Yellow Bands at 300mm intervals, or Black and Yellow Tape used to a height of 1.8 metres.
5. Scaffolds must be tied every 32 square metres, or if to be sheeted down 25 square metres. Reveal ties are not to be used on their own and when used with other ties a maximum of 50% only is permitted and these should be checked daily. When drilled anchorages are used, their capacity should be to British Standard.
6. Ladders should be sound and 'lashed' and go at least 5 rungs or 1.1m above any working lift.
7. Hand rails must be fixed on all working lifts with ladder access.
8. Toe boards must be fixed to all working lifts including end boards.
9. All working lift boards (excluding toe boards) are to be banded (including any shortened boards).
10. All scaffolds must be lit during hours of darkness.
11. The Erectors Board (Scaffolders only) must be fixed in a prominent position, complete with emergency telephone number for use by Emergency Services.
12. Balking will be required where the scaffolding is less than 450mm (18") distance from the carriageway or if no pavement is provided, this consists of heavy timber sleepers with upright posts and sight rails fixed and painted red and white, flashing amber lights must be fixed to the uprights and an arrow board (dia. 610) provided complete with a sandbag weight as per the attached drawing.
13. A Hand Rail and Tap Board must be provided at ground level to assist the blind and partially sighted through the obstruction and the clips wrapped or covered for protection.

in partnership with



**Nottinghamshire
County Council**

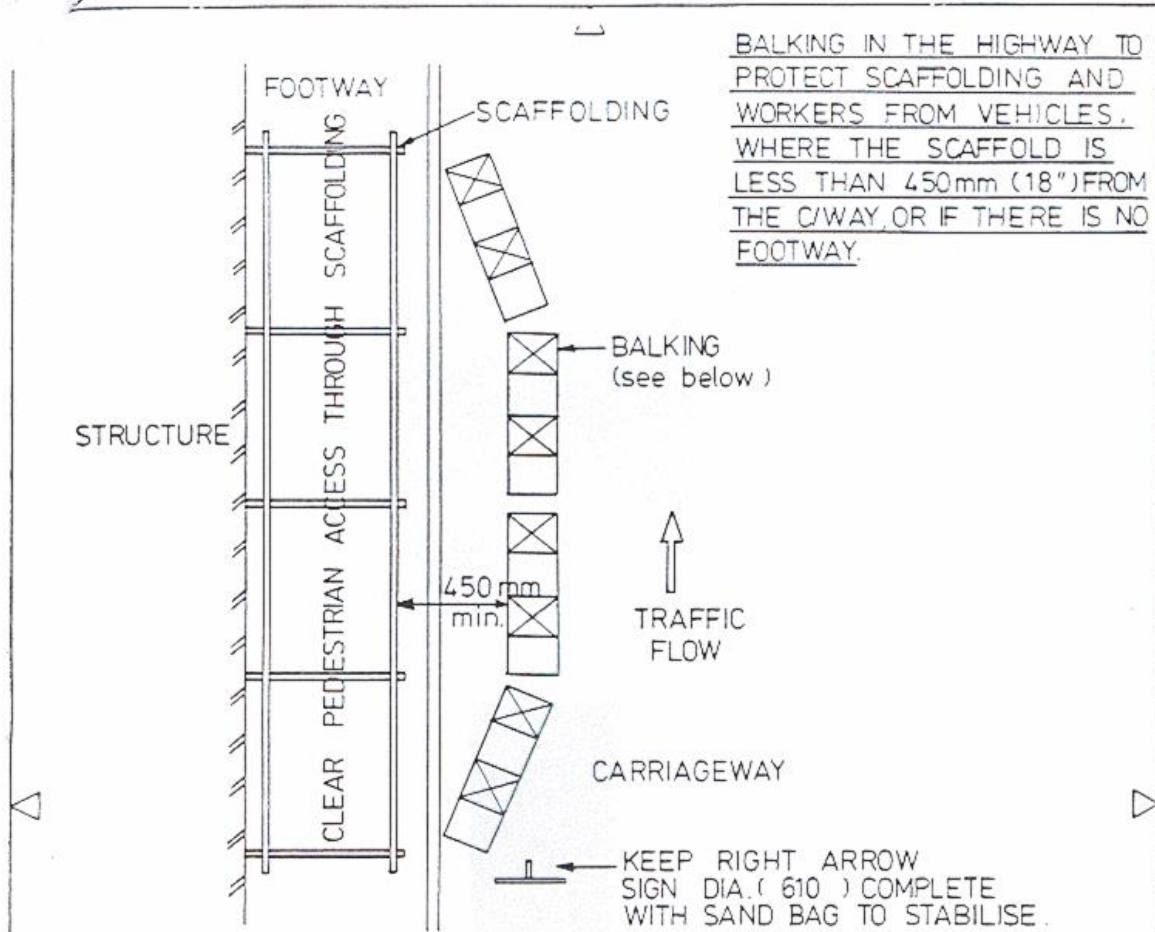

PLAN - NOT TO SCALE

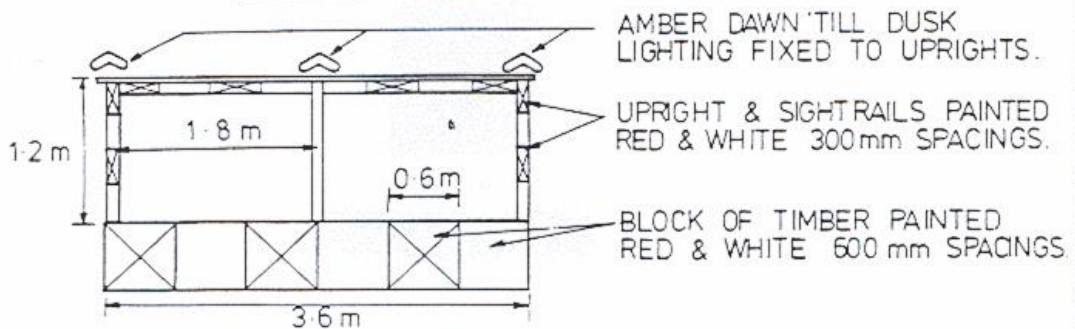

ELEVATION - SCALE 1:5



Nottinghamshire
County Council
Construction and Design
Director
Trent Bridge House, Fox Road
West Bridgford, Nottingham NG2 6BJ
Tel (0115) 982 3823

Project:	BALKING IN THE HIGHWAY	Date	2 - 92
Org. no.	M / 02033 / 1A	Drawn	
Revision		Traced	
		Checked	
		Scale	