

**11.0****Cycle Parking**

The lack of safe and secure places to park cycles is cited by both existing and potential cyclists as one of the major deterrents to cycling. If cycle parking facilities are not provided, then cycles are often chained to lamp columns, railings and posts, which is unsightly and can often be hazardous to pedestrians.



Photo 11.1

**Photos 11.1 and 11.2**

A lack of cycle parking leads to clutter; a potential pedestrian hazard and a lack of security for the bike.



Photo 11.2

**11.1****Where Should Cycle Parking Facilities be provided?**

Unless cycle parking is provided in the correct location, it will not be used.

There are 2 main types of cycle parking *SHORT TERM* and *LONG TERM*

1. For *short term*, the cycle parking should be placed as close as possible to the trip end point such as entrance to shops, leisure centre, town centre etc as cyclists prefer not to walk long distances once they have parked. Sheffield Stands are ideal for this purpose (see 11.4)
2. For *longer term* parking (i.e. all day) cyclists may be prepared to walk further for the facility. These facilities may take the form of more secure cycle parking such as lockers or undercover stands at workplaces and rail stations.

**Remember**

- to locate all stands out of pedestrian desire lines, but in busy, well lit areas. If however, the cycle parking is within a pedestrian area, consider providing it on a base that contrasts in colour to the rest of the footway
- to provide signing towards the stand and signing at the stands themselves so that potential users can find the stands
- to check the land ownership issues, and ensure that the location of the stands does not conflict with the maintenance of other facilities
- for new developments see NCC 'Parking Provision for New Developments' (or 11.5)

For additional info on Cycle Parking, please refer to Traffic Advisory Leaflet 05/02  
[http://www.dft.gov.uk/stellent/groups/dft\\_roads/documents/page/dft\\_roads\\_504716.hcsp](http://www.dft.gov.uk/stellent/groups/dft_roads/documents/page/dft_roads_504716.hcsp)

## 11.2 Financing Cycle Parking Schemes

- Money can be made available for cycle parking from the LTP and from district councils.
- An alternative source of funding is from developer contributions.
- Although monies are available, there have been problems in getting agreements to site the stands/facilities where they are required. Please contact the Cycling/ Walking Officer for assistance.

## 11.3 What Types of Cycle Parking Facilities are Available?

### 11.3.1 Sheffield Stands

- A relatively cheap, easy to implement and readily understood form of cycle parking.
  - Use 37-80mm diameter steel tubing (stainless or galvanised)
  - They have a design life of 20 years (with mid-life repaint)
  - Spacing between stands should be 1.0m *Fig 11.A*
  - Height 0.75m (not higher than 0.8m), Length 0.7 - 1.2m, Spacing between stand and wall 0.5m
  - The stands can also be placed at an angle where space is limited by width (see photo)
  - Do not locate too close to wall, or place them such that an attached bike would stick out into the footway/carriageway.
  - 'Toast rack' stands are form a solid frame which can be fixed to flat, hard surfaces such as pavements and platforms by means of a few fixing bolts, without the need to excavate holes. They can be easily relocated if necessary, but can be less visually appealing. Sheffield stands should be considered first.
  - Provide colour contrast bands/strips on the stands to aid partially sighted people.
- The preferred stand design is shown in photo 11.4 and Fig 11.B**

Fig 11.A

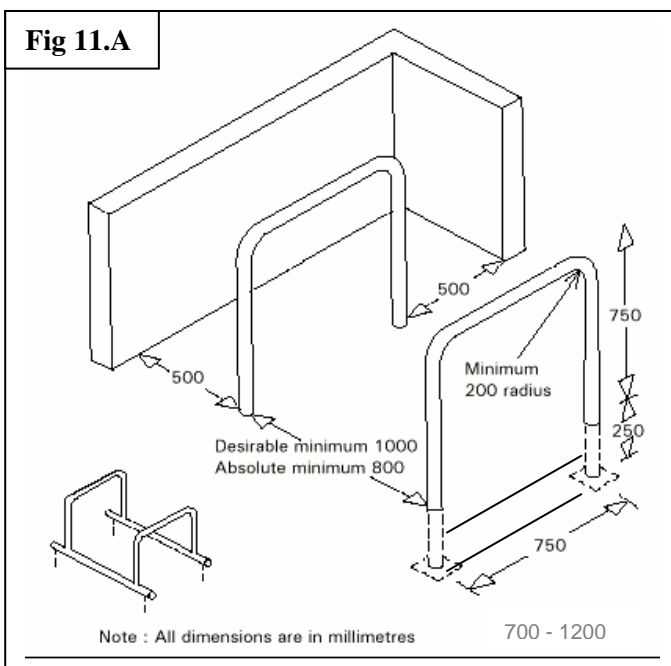

Photo 11.3



Photo 11.4



11.3 'Toast Rack'

11.4 The preferred layout, Sheffield stand with crossbar, signing and reflectorised bands

What types of cycle parking facilities are available? Continued...

11.3.2

Butterfly Loops

These stands take up little room and are inexpensive, but only provide a limited amount of security (you may return to your bike to find that only the front wheel remains). As such these stands are little used by cyclists.

DO NOT USE THESE STANDS FOR FUTURE INSTALLATIONS



Photo 11.5 Butterfly loops offer limited protection from theft.

11.3.3

Cycle Lockers

**Advantages:** A hidden bike is more secure than one out in the open, is protected from the elements and also allows secure storage of panniers, helmet and clothing. Good for longer term parking at rail stations and work places (see photos 11.6 - 11.8)

**Disadvantages:** More expensive than Sheffield stands, and they take up more space (particularly in town centres). They are open to misuse:

- some users try to claim a locker as their own (preventing others from using it) by keeping their lock secured on the locker when their bike is not in
- it has been reported that some lockers have been used by the homeless as a bed for the night, and by others as a secure storage area for drugs
- regular cleaning of the lockers is essential as they can collect leaves and litter.

**Maintenance must be arranged and agreed prior to installation. It is preferable if lockers are located where they can be attended to most days - e.g. stations.**



Photo 11.6



Photo 11.7



Photo 11.8

*Signing on the lockers must inform people how to use the lockers, and the consequences of failing to use them properly. e.g. "Regular inspections are carried out. If the locker is found to be empty then locks will be removed. Cycles left longer than 24 hours may be removed".*

**11.4**

**Work-Place Cycle Parking**

- Cycle parking should be secure and undercover in order to give cyclists the confidence to leave their cycles
- Standards for the amount of cycle parking required at new developments are shown in 11.5
- Employers can provide secure cycle parking in cages or buildings, or can provide individual secure lockers. In addition covered Sheffield stands can be provided
- Security can be improved through the use of CCTV, communal keys, swipe cards, and lighting, however natural surveillance is the most effective
- Shower and changing facilities should be provided where possible



**Photo 11.9**

In addition see TAL 11/97 on Cycling to Work  
[http://www.dft.gov.uk/stellent/groups/dft\\_roads/documents/page/dft\\_roads\\_504737.hcsp](http://www.dft.gov.uk/stellent/groups/dft_roads/documents/page/dft_roads_504737.hcsp)

**Photo 11.9**

Covered Sheffield Stands provided at Hazlewoods food site, Manton Wood Enterprise Zone, Worksop

**Photo 11.10**

Very grand! Cycle parking at Cambridge University  
 Courtesy Cambridge Cycling Campaign



**Photo 11.10**

## 11.5 Nottinghamshire CC Draft Cycle Parking Standards for New Developments

Use Class	Minimum Provision (Gross Floor Area)
A1 - Retail	1/200m <sup>2</sup>
B1 - Business	1 per 100m <sup>2</sup>
B2 - General Industrial	1 per 200m <sup>2</sup>
B8 - Storage and Distribution	1 per 400m <sup>2</sup>
C1 - Hotels	1 per 5 staff
C2 - Residential Institutions	1 per 5 staff
C3 - flats/townhouses	1 per dwelling
C3 - Halls of residence	1 per 3 students
D1 - Non Residential (other than education)	1 per 5 staff
D1 - Non Residential - education	To be determined via a school travel plan with a greater provision for older students (for a contact see 1.4)
D2 - Leisure(Leisure Centres)	1 per 5 staff plus 1/5 for maximum number of visitors

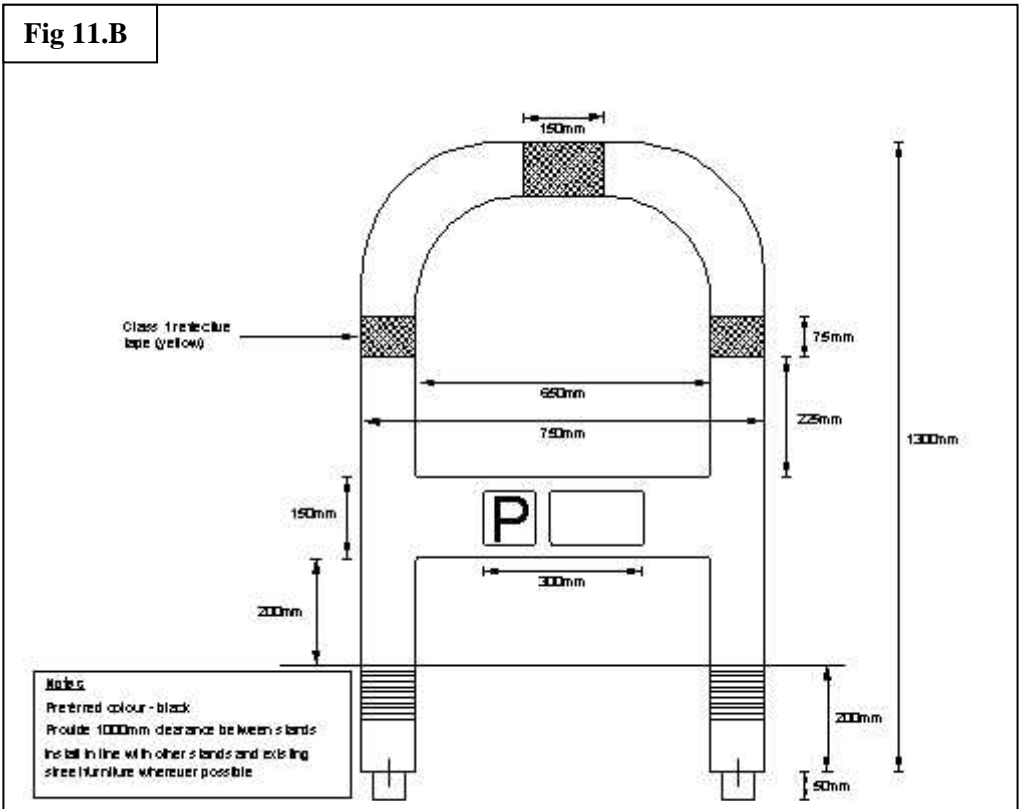

**Fig 11.B**  
 Dimensions for preferred design of Sheffield stand. Includes 'P' and cycle logo, as well as reflectorised bands to assist people with visual impairments. For more info contact NCC Cycling & Walking Officer.

11.6

Signage for Cycle Parking

- It is essential to provide signage at the cycle parking to highlight its presence. Some cycle parking facilities can be hard to spot in areas with lots of street furniture and therefore they may not be fully utilised. (see photo 11.11)
- The parking symbol to *diagram 968/968.1* MUST be provided on all new facilities.
- At cycle lockers, provide signage indicating how to use the lockers, and the consequences of failing to use them properly
- Use signing to direct cyclists towards the facility
- Incorporate signing into the stand (see photo 11.4)



**Photo 11.11** Sheffield stands are provided but they are difficult to spot and subsequently are not well used. Signing would help to make them more visible and may prevent cycles being chained to lamp posts/ railings.



**Photo 11.12** Example of direction signing to cycle parking (note this is on a car park sign)

11.7

Legal Issues

The County Council is empowered under *Section 63 of the Road Traffic Regulation Act 1984* and under the *Highways Act 1980* to provide stands or racks for bicycles in roads or elsewhere. These powers are linked to those enabling the authority to provide parking places.

**Photo 11.13**  
Parking sign at locker



11.8

Rural Cycle Parking

For information on preferred materials and locations, please contact The Recreational Routes Officer on 01623 861406

Further information is also available in the National Trust Cycle Parking Guide  
<http://www.nationaltrust.org.uk/environment/html/cproject/pdf/cycle01.pdf>